

MS Bench SCI 1

Application: MS Bench (G) SCI for SCIEX LC-MS instruments (excluding IVD medical device instruments) MS Bench SCI for SCIEX LC-MS Instruments (including housing floor-standing Triple TOFs vac pump)

Part number: 3302382



Description

Developed exclusively for SCIEX, the MS Bench SCI range provides a modular workstation with provision for either integrated gas generation or a noise abating enclosure for roughing pumps. MS Bench SCI is designed specifically for use with the current and latest mass spectrometers at SCIEX*.

Two variants of the MS SCI Bench are available, both identical in form factor, aesthetics and work surface. MS Bench (G) SCI 1 features a self contained gas generator, providing a reliable and cost-efficient source of both nitrogen (Curtain Gas™) and clean, dry oil-free air for source and exhaust gas at flows and pressures configured to meet SCIEX instrument requirements (excluding IVD medical devices). The other variant, the MS Bench SCI, comes without the gas generator, instead providing a compartment below the bench, suitable for housing up to two MS roughing pumps.

- **Application Types:** MS Bench (G) SCI for SCIEX LC-MS instruments (excluding IVD medical device instruments) MS Bench SCI for SCIEX LC-MS Instruments (including housing floor-standing Triple TOFs vac pump)

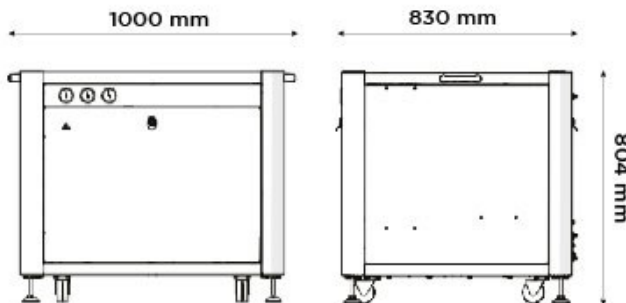

Key Features

- Designed exclusively for SCIEX to provide modular bench solution for all SCIEX LC-MS instruments*
- Noise abated compartment suitable for housing vacuum pump(s) (non generator variant only) 'Genius Inside': true plug & play gas generation (MS Bench (G) SCI 1 only).
- No external compressed air source required.
- Noise & vibration dampening, suitable for use as instrumentation bench CSA / FCC / CE compliant
- Chemical-resistant phenolic resin worktop
- Self-levelling castor wheels for seamless installation with existing lab bench system
- Floor-standing Triple TOFs can house vac pumps in MS Bench SCI.

*suitable for all current and latest MS from SCIEX including the new 5500+, but excluding IVD medical device instrument.

Technical Specifications

	MS Bench SCI 1
Max Gas Flow:	VariableL/min
Power Consumption:	200VA
Voltage:	100 - 240v ±10%
Frequency:	50/60 Hz
Current:	2 Amps
Heat output:	784 BTU/hr
Max Operating Temp:	30°C / 86°F
Noise Level:	54 (dB)
Size (HxWxD) mm	804 x 1000 x 830 mm
Size (HxWxD) Inches	31.7 x 39.4 x 32.7 inches
Generator Weight	103kg / 226.6lbs
Max Weight Bearing Capability	272kg / 598.4lbs

[PEAK Protected]TM

Peak Scientific gas generators define the benchmark in reliability, convenience and performance in laboratories around the world, and come backed with a 12 month warranty. Beyond this period however you can ensure that your investment continues to be **[Protected]** by our comprehensive generator care cover.

Our world-class aftercare support packages deliver a program of scheduled preventative maintenance whilst giving you the reassurance of instant access to worldwide technical support and priority on-site response in the untimely event of a breakdown.

- For ordering parts visit: www.peakscientific.com/ordering/
- For service plans visit: www.peakscientific.com/service/service-plans/

Peak Scientific UK
Tel: +44 (0)141 812 8100
Fax: +44 (0)141 812 8200

Peak Scientific North America
Tel: +1-800-767-6532
Fax: +1-978-608-9503

Peak Scientific China
Tel: +86 21 5079 1190
Fax: +86 21 5079 1191
For a full list of our worldwide office locations, please visit:
Web: www.peakscientific.com
Email: discover@peakscientific.com

Peak Scientific's Quality Management System conforms to: ISO:9001



0003