

# MS Bench SCI 2

Part number: 3303000



## Description

Developed exclusively for SCIEX, the MS Bench SCI 2 range provides a modular workstation with provision for either integrated gas generation or a noise abating enclosure for roughing pumps. MS Bench SCI 2 is designed specifically for use with the SCIEX Triple Quad™ 7500 LC-MS/MS System– QTRAP® Ready.

Two variants of the MS Bench SCI 2 are available. MS Bench (G) SCI 2 features a self-contained gas generator, providing a reliable and cost efficient source of both nitrogen (Curtain Gas™) and clean, dry oil-free air for source and exhaust gas at flows and pressures configured to meet SCIEX 7500 System requirements. The other variant, the MS Bench SCI 2, comes without the gas generator, instead providing a compartment below the bench, suitable for housing up to two MS roughing pumps.



## Application Types

SCIEX Triple Quad™ 7500 LC-MS/MS System– QTRAP® Ready

## Generator Details

- **Gas types:** Air, Air Category

## Key Features

- Designed exclusively for SCIEX to provide modular bench solution for SCIEX Triple Quad™ 7500 LC-MS/MS System– QTRAP® Ready
- Noise abated compartment suitable for housing vacuum pump(s) (non generator variant only)
- 'Genius Inside': true plug & play gas generation (MS Bench (G) SCI 2 only)
- No external compressed air source required
- Noise & vibration dampening, suitable for use as instrumentation bench
- Fan assisted cooling for vacuum pumps
- Reclassifier vent preventing internal condensation (MS Bench (G) SCI 2 only)
- CSA / FCC / CE compliant
- Chemical-resistant phenolic resin worktop
- Levelling castor wheels for seamless installation with existing lab bench system

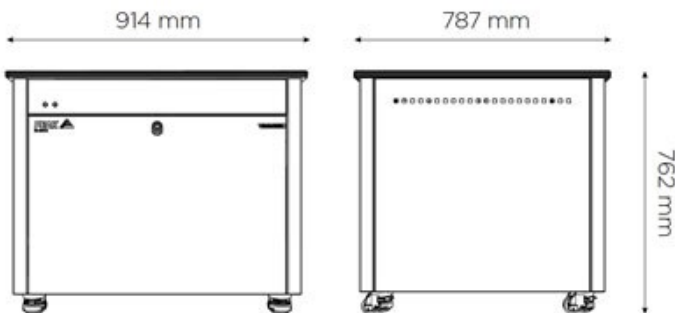

## Technical Specifications

	MS Bench SCI 2
Max Gas Flow:	VariableL/min
Power Consumption:	240
Frequency:	60 Hz
Max Operating Temp:	30°C / 86°F
Noise Level:	noise abating to 60 dB(A)
Accreditations:	CE, FCC, CSA
Size (HxWxD) mm	762 x 1041 x 787 mm
Size (HxWxD) Inches	30 x 41 x 31 inches
Generator Weight	103kg / 226.6lbs

# [PEAK Protected]<sup>TM</sup>

Peak Scientific gas generators define the benchmark in reliability, convenience and performance in laboratories around the world, and come backed with a 12 month warranty. Beyond this period however you can ensure that your investment continues to be **[Protected]** by our comprehensive generator care cover.

Our world-class aftercare support packages deliver a program of scheduled preventative maintenance whilst giving you the reassurance of instant access to worldwide technical support and priority on-site response in the untimely event of a breakdown.

- For ordering parts visit: [www.peakscientific.com/ordering/](http://www.peakscientific.com/ordering/)
- For service plans visit: [www.peakscientific.com/service/service-plans/](http://www.peakscientific.com/service/service-plans/)

**Peak Scientific UK**  
Tel: +44 (0)141 812 8100  
Fax: +44 (0)141 812 8200

**Peak Scientific North America**  
Tel: +1-800-767-6532  
Fax: +1-978-608-9503

**Peak Scientific China**  
Tel: +86 21 5079 1190  
Fax: +86 21 5079 1191  
For a full list of our worldwide office locations, please visit:  
Web: [www.peakscientific.com](http://www.peakscientific.com)  
Email: [discover@peakscientific.com](mailto:discover@peakscientific.com)

Peak Scientific's Quality Management System conforms to: ISO:9001

