

AMD 200

Air Membrane Dryer

Part number: 3302252



Description

Capable of flow rates up to 200 L/min, the AMD 200 Air Membrane Dryer is compatible with any compressed air source, offering a compact and lightweight must-have for any modern laboratory requiring instrument grade air. With no moving parts, AMD 200 is effectively silent in operation. This dryer also has very low maintenance requirements, delivering a cost effective source of clean, dry instrument grade air from your existing compressed air supply for the laboratory.



Application Types

LC-MS requiring dry air Other laboratory applications requiring dry air

Generator Details

- **Gas types:** Air
- **Integrated compressor:** No

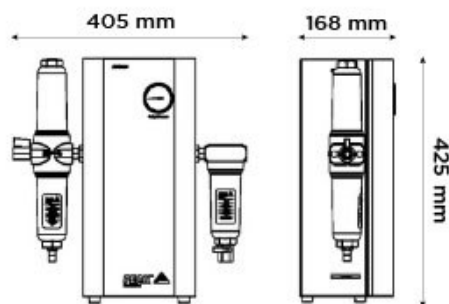

Key Features

- Variable flow up to 200 L/min
- Variable pressure up to 120 psi
- Clean, dry instrument grade air
- Compact, space saving design
- Completely silent in operation
- No moving parts means minimum maintenance requirements and ensures long life 24/7 operation at optimum performance if required
- Generator only needs to be connected to the air source and application

Technical Specifications

	AMD 200
Gas Type	Air
Max Gas Flow:	200L/min
Max Output Pressure:	120psi/8.3bar
Max Output Pressure:	120psi/8.3bar
Max Purity:	99.50%
Gas Outlets Fitting:	1 x 1/4 " BSPP
Min Inlet Pressure:	110psi/7.6bar
Max Inlet Pressure:	145psi/10bar
Min Inlet Air Quality:	ISO 8753-1:2010 Class 1.4.1
Max Operating Temp:	35°C / 95°F
Phthalates:	Phthalate & BHT Free
Size (HxWxD) mm	425 x 405 x 168 mm
Size (HxWxD) Inches	16.7 x 15.9 x 6.6 inches
Generator Weight	8kg / 17.6lbs

[PEAK Protected]TM

Peak Scientific gas generators define the benchmark in reliability, convenience and performance in laboratories around the world, and come backed with a 12 month warranty. Beyond this period however you can ensure that your investment continues to be **[Protected]** by our comprehensive generator care cover.

Our world-class aftercare support packages deliver a program of scheduled preventative maintenance whilst giving you the reassurance of instant access to worldwide technical support and priority on-site response in the untimely event of a breakdown.

- For ordering parts visit: www.peakscientific.com/ordering/
- For service plans visit: www.peakscientific.com/service/service-plans/

Peak Scientific UK
Tel: +44 (0)141 812 8100
Fax: +44 (0)141 812 8200

Peak Scientific North America
Tel: +1-800-767-6532
Fax: +1-978-608-9503

Peak Scientific China
Tel: +86 21 5079 1190
Fax: +86 21 5079 1191
For a full list of our worldwide office locations, please visit:
Web: www.peakscientific.com
Email: discover@peakscientific.com

Peak Scientific's Quality Management System conforms to: ISO:9001

