

# MS Table

Part number: 10-9900



## Description

The MS table has been designed as an SCIEX exclusive product to house the Triple Quad™, QTRAP™ or IVD MS systems. The MS table comes in a standard and premium form, the premium version including an inbuilt Infinity 1031, or 1031 Hi-flow for MD instruments, allowing the supply of curtain, source and exhaust gases. Furthermore, the MS Table also comes supplied with an accessible sound proof enclosure for the required vacuum pumps for these applications.



## Application Types

Suitable for all SCIEX LC-MS excluding X500 Series and MD

## Generator Details

- **Gas types:** Air
- **Integrated compressor:** No

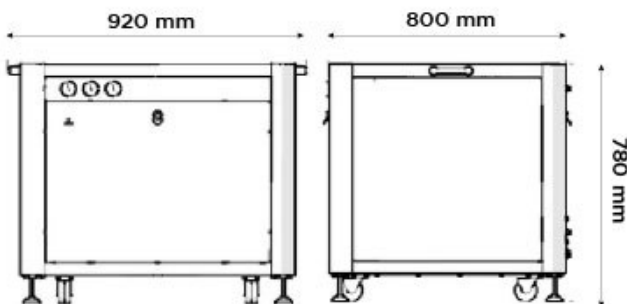

## Key Features

- Table designed to hold SCIEX Mass Spectrometer
- Can be supplied on its own or with an integrated nitrogen generator
- Reduced lab footprint
- Minimal set-up required Sound proofed reducing noise of generator

## Technical Specifications

### MS Table 1B

Gas Type	Air
Accreditations:	CE
Size (HxWxD) mm	780 x 920 x 800 mm
Size (HxWxD) Inches	30.7 x 36.2 x 31.5 inches
Generator Weight	100kg / 220lbs

# [PEAK Protected]<sup>TM</sup>

Peak Scientific gas generators define the benchmark in reliability, convenience and performance in laboratories around the world, and come backed with a 12 month warranty. Beyond this period however you can ensure that your investment continues to be **[Protected]** by our comprehensive generator care cover.

Our world-class aftercare support packages deliver a program of scheduled preventative maintenance whilst giving you the reassurance of instant access to worldwide technical support and priority on-site response in the untimely event of a breakdown.

- For ordering parts visit: [www.peakscientific.com/ordering/](http://www.peakscientific.com/ordering/)
- For service plans visit: [www.peakscientific.com/service/service-plans/](http://www.peakscientific.com/service/service-plans/)

**Peak Scientific UK**  
Tel: +44 (0)141 812 8100  
Fax: +44 (0)141 812 8200

**Peak Scientific North America**  
Tel: +1-800-767-6532  
Fax: +1-978-608-9503

**Peak Scientific China**  
Tel: +86 21 5079 1190  
Fax: +86 21 5079 1191  
For a full list of our worldwide office locations, please visit:  
Web: [www.peakscientific.com](http://www.peakscientific.com)  
Email: [discover@peakscientific.com](mailto:discover@peakscientific.com)

Peak Scientific's Quality Management System conforms to: ISO:9001

